

# GS 2. — 24. veljače 2026.

## Zadatak 1.

Inženjerskom metodom pomakā nacrtajte dijagrame unutarnjih sila!

$$t_s = 30^\circ C \text{ (na štapu } \{2,4\})$$

$$\alpha_t = 1 \cdot 10^{-5} K^{-1}$$

$$\bar{u}_2 = 3 \text{ cm}$$

$$\bar{w}_2 = 2 \text{ cm}$$

$$EI = 20250 \text{ kNm}^2$$

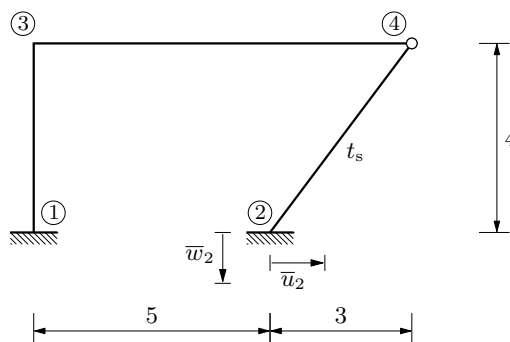

zglobna shema:

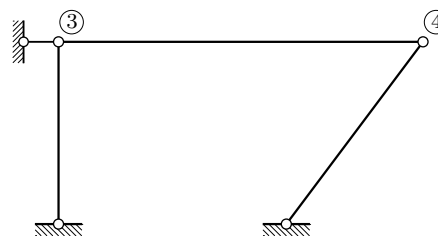
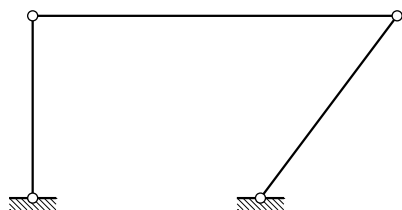

četverozglobni okvir:  
„elementarni” mehanizam  
s jednim stupnjem slobode

sistem sa spriječnim pomakom:  
čvor 3 nepomičan → čvor 4 nepomičan

nepoznanice:  $\varphi_3, u_{\{3,4\}}$

plan pomakā (zora radi) i dijagram projekcija pomakā na horizontalni pravac za  $u_{\{3,4\}}$ :

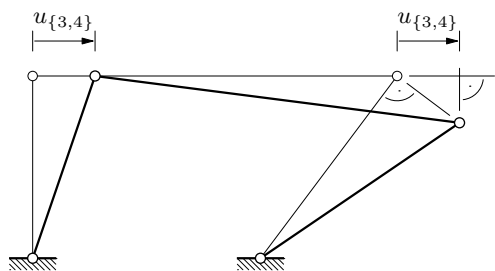

$$\psi_{\{1,3\}} = \psi_{\{2,4\}} = \psi_{\text{I}} = \psi_{\text{III}} = -\frac{u_{\{3,4\}}}{4}$$

$$h : 8 = 4 : 3 \Rightarrow h = \frac{32}{3}$$

$$\psi_{\{3,4\}} = \psi_{\text{II}} = -\frac{u_{\{3,4\}}}{h} = -\frac{3 u_{\{3,4\}}}{32}$$

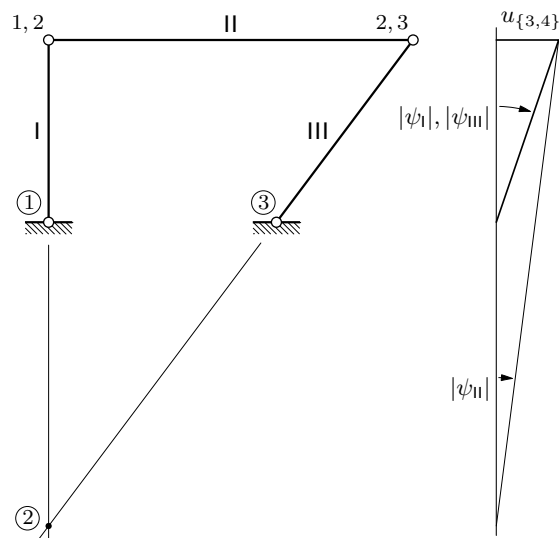

izrazi za vrijednosti momenata na krajevima štapova:

$$M_{1,3} = 2 k_{\{1,3\}} \varphi_3 - 6 k_{\{1,3\}} \psi_{\{1,3\}} + \bar{M}_{1,3} = 2 \frac{EI}{4} \varphi_3 - 6 \frac{EI}{4} \left( -\frac{u_{\{3,4\}}}{4} \right) + \bar{M}_{1,3}$$

$$= \frac{EI}{2} \varphi_3 + \frac{3EI}{8} u_{\{3,4\}} + \bar{M}_{1,3} = 10\,125 \varphi_3 + 7\,593,75 u_{\{3,4\}} + \bar{M}_{1,3}$$

$$M_{3,1} = 4 k_{\{1,3\}} \varphi_3 - 6 k_{\{1,3\}} \psi_{\{1,3\}} + \bar{M}_{3,1} = 20\,250 \varphi_3 + 7\,593,75 u_{\{3,4\}} + \bar{M}_{3,1}$$

$$M_{3,4} = 3 k_{\{3,4\}} \varphi_3 - 3 k_{\{3,4\}} \psi_{\{3,4\}} + \bar{M}_{3,4} = 3 \frac{EI}{8} \varphi_3 - 3 \frac{EI}{8} \left( -\frac{3 u_{\{3,4\}}}{32} \right) + \bar{M}_{3,4}$$

$$= \frac{3EI}{8} \varphi_3 + \frac{9EI}{256} u_{\{3,4\}} + \bar{M}_{3,4} = 7\,593,75 \varphi_3 + 711,91 u_{\{3,4\}} + \bar{M}_{3,4}$$

$$M_{2,4} = -3 k_{\{2,4\}} \psi_{\{2,4\}} + \bar{M}_{2,4} = -3 \frac{EI}{5} \left( -\frac{u_{\{3,4\}}}{4} \right) + \bar{M}_{2,4}$$

$$= \frac{3EI}{20} u_{\{3,4\}} + \bar{M}_{2,4} = 3\,037,5 u_{\{3,4\}} + \bar{M}_{2,4}$$

jednadžba ravnoteže momenata u čvoru 3:

$$-M_{3,1} - M_{3,4} = 0 \quad \Rightarrow \quad M_{3,1} + M_{3,4} = 0$$

$$20\,250 \varphi_3 + 7\,593,75 u_{\{3,4\}} + \bar{M}_{3,1} + 7\,593,75 \varphi_3 + 711,91 u_{\{3,4\}} + \bar{M}_{3,4} = 0$$

$$27\,843,75 \varphi_3 + 8\,305,66 u_{\{3,4\}} = -\bar{M}_{3,1} - \bar{M}_{3,4}$$

jednadžba rada na virtualnom pomaku  $\delta u_{\{3,4\}}$ :

$$(M_{1,3} + M_{3,1}) \delta \psi_{\{1,3\}} + M_{2,4} \delta \psi_{\{2,4\}} + M_{3,4} \delta \psi_{\{3,4\}} = 0$$

$$(M_{1,3} + M_{3,1}) \left( -\frac{\delta u_{\{3,4\}}}{4} \right) + M_{2,4} \left( -\frac{\delta u_{\{3,4\}}}{4} \right) + M_{3,4} \left( -\frac{3 \delta u_{\{3,4\}}}{32} \right) = 0 \quad \forall \delta u_{\{3,4\}}$$

$$-\frac{1}{4} (M_{1,3} + M_{3,1}) - \frac{1}{4} M_{2,4} - \frac{3}{32} M_{3,4} = 0$$

$$-\frac{1}{4} (10\,125 \varphi_3 + 7\,593,75 u_{\{3,4\}} + \bar{M}_{1,3} + 20\,250 \varphi_3 + 7\,593,75 u_{\{3,4\}} + \bar{M}_{3,1})$$

$$- \frac{1}{4} (3\,037,5 u_{\{3,4\}} + \bar{M}_{2,4}) - \frac{3}{32} (7\,593,75 \varphi_3 + 711,91 u_{\{3,4\}} + \bar{M}_{3,4}) = 0$$

$$-8\,305,66 \varphi_3 - 4\,622,99 u_{\{3,4\}} - \frac{1}{4} (\bar{M}_{1,3} + \bar{M}_{3,1} + \bar{M}_{2,4}) - \frac{3}{32} \bar{M}_{3,4} = 0$$

$$8\,305,66 \varphi_3 + 4\,622,99 u_{\{3,4\}} = -\frac{1}{4} (\bar{M}_{1,3} + \bar{M}_{3,1} + \bar{M}_{2,4}) - \frac{3}{32} \bar{M}_{3,4}$$

$$K = \begin{bmatrix} 27\,843,75 & 8\,305,66 \\ 8\,305,66 & 4\,622,99 \end{bmatrix} \quad \dots \text{simetrična matrica (provjera)}$$

plan pomakā (zora radi, dakako) i dijagrami projekcija pomakā za  $\bar{u}_2$ :

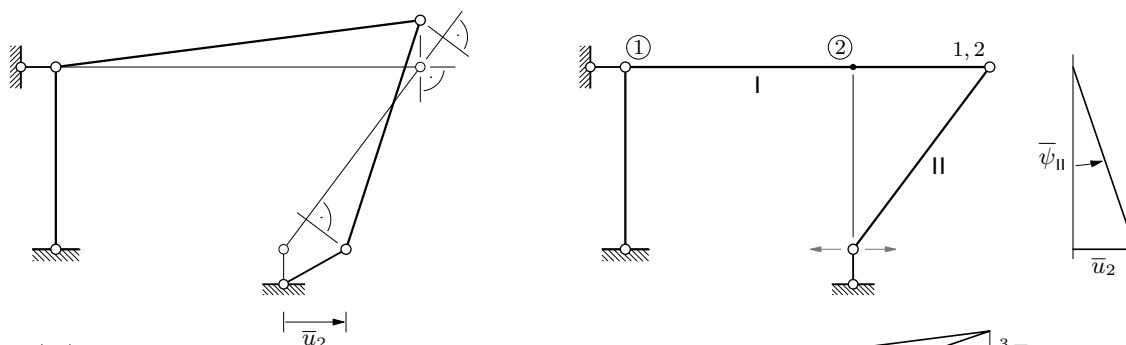

$$\bar{\psi}_{\{1,3\}}^{(\bar{u}_2)} = 0$$

$$\bar{\psi}_{\{2,4\}}^{(\bar{u}_2)} = \bar{\psi}_{II} = \frac{\bar{u}_2}{4} = \frac{0,03}{4} = 0,0075$$

$$\bar{\psi}_{\{3,4\}}^{(\bar{u}_2)} = \bar{\psi}_I = \frac{3}{4} \frac{\bar{u}_2}{4} = \frac{3}{32} \bar{u}_2 = 0,0028$$

za mehanizam prikazan na desnom crtežu dijagrami projekcija i plan pomakā jednaki su kao za mehanizam prikazan na gornjem crtežu (tijelo I je nepomično, pa se polovi tijela II i III poklapaju s polovima tijela I i II)

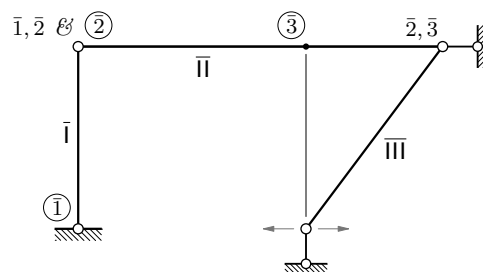

vrijednosti momenata upetosti za  $\bar{u}_2$ :

$$\bar{M}_{1,3}^{(\bar{u}_2)} = \bar{M}_{3,1}^{(\bar{u}_2)} = 0$$

$$\bar{M}_{2,4}^{(\bar{u}_2)} = -3 k_{\{2,4\}} \bar{\psi}_{\{2,4\}}^{(\bar{u}_2)} = -3 \frac{EI}{5} 0,0075 = -91,13 \text{ kNm}$$

$$\bar{M}_{3,4}^{(\bar{u}_2)} = -3 k_{\{3,4\}} \bar{\psi}_{\{3,4\}}^{(\bar{u}_2)} = -3 \frac{EI}{8} 0,0028 = -21,26 \text{ kNm}$$

$$-\bar{M}_{3,1}^{(\bar{u}_2)} - \bar{M}_{3,4}^{(\bar{u}_2)} = 21,26$$

$$-\frac{1}{4} (\bar{M}_{1,3}^{(\bar{u}_2)} + \bar{M}_{3,1}^{(\bar{u}_2)} + \bar{M}_{2,4}^{(\bar{u}_2)}) - \frac{3}{32} \bar{M}_{3,4}^{(\bar{u}_2)} = 24,78$$

sustav jednačbi za  $\bar{u}_2$  i rješenje:

$$27\,843,75 \varphi_3^{(\bar{u}_2)} + 8\,305,66 u_{\{3,4\}}^{(\bar{u}_2)} = 21,26$$

$$8\,305,66 \varphi_3^{(\bar{u}_2)} + 4\,622,99 u_{\{3,4\}}^{(\bar{u}_2)} = 24,78$$

$$\varphi_3^{(\bar{u}_2)} = -0,00180 \quad \& \quad u_{\{3,4\}}^{(\bar{u}_2)} = 0,008594 \text{ m}$$

vrijednosti momenata na krajevima štapova za  $\bar{u}_2$ :

$$M_{1,3}^{(\bar{u}_2)} = 10\,125 \varphi_3^{(\bar{u}_2)} + 7\,593,75 u_{\{3,4\}}^{(\bar{u}_2)} + \bar{M}_{1,3}^{(\bar{u}_2)}$$

$$= 10\,125 \cdot (-0,00180) + 7\,593,75 \cdot 0,008594 + 0 = 47,04 \text{ kNm}$$

$$\begin{aligned}
M_{3,1}^{(\bar{u}_2)} &= 20\,250 \varphi_3^{(\bar{u}_2)} + 7\,593,75 u_{\{3,4\}}^{(\bar{u}_2)} + \bar{M}_{3,1}^{(\bar{u}_2)} \\
&= 20\,250 \cdot (-0,001\,80) + 7\,593,75 \cdot 0,008\,594 + 0 = 28,81 \text{ kNm} \\
M_{3,4}^{(\bar{u}_2)} &= 7\,593,75 \varphi_3^{(\bar{u}_2)} + 711,91 u_{\{3,4\}}^{(\bar{u}_2)} + \bar{M}_{3,4}^{(\bar{u}_2)} \\
&= 7\,593,75 \cdot (-0,001\,80) + 711,91 \cdot 0,008\,594 - 21,26 = -28,81 \text{ kNm} \\
M_{2,4}^{(\bar{u}_2)} &= 3\,037,5 u_{\{3,4\}}^{(\bar{u}_2)} + \bar{M}_{2,4}^{(\bar{u}_2)} = 3\,037,5 \cdot 0,008\,594 - 91,13 = -65,03 \text{ kNm}
\end{aligned}$$

plan pomakā i dijagram projekcija pomakā na vertikalni pravac za  $\bar{w}_2$ :

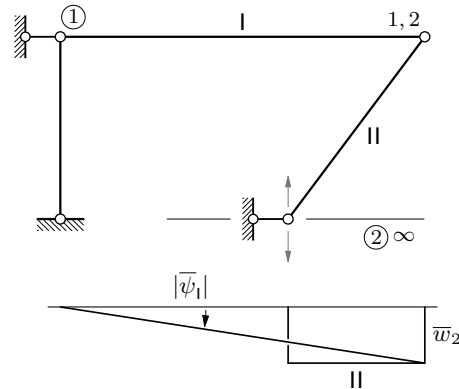
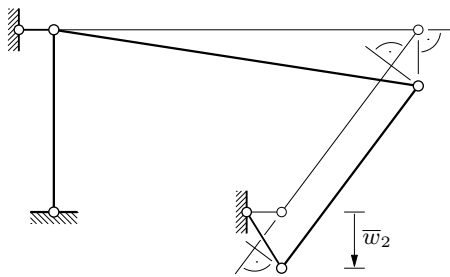

$$\begin{aligned}
\bar{\psi}_{\{1,3\}}^{(\bar{w}_2)} &= 0 \\
\bar{\psi}_{\{2,4\}}^{(\bar{w}_2)} &= \bar{\psi}_{\text{II}} = 0 \\
\bar{\psi}_{\{3,4\}}^{(\bar{w}_2)} &= \bar{\psi}_{\text{I}} = -\frac{\bar{w}_2}{8} = -0,002\,5
\end{aligned}$$

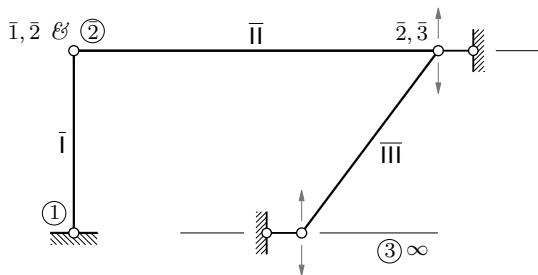

dijagrami projekcija i plan pomakā jednaki su za mehanizme prikazane na lijevoj i na gornjem crtežu iz istih razloga kao na prethodnoj stranici

vrijednosti momenata upetosti za  $\bar{w}_2$ :

$$\begin{aligned}
\bar{M}_{1,3}^{(\bar{w}_2)} &= \bar{M}_{3,1}^{(\bar{w}_2)} = \bar{M}_{2,4}^{(\bar{w}_2)} = 0 \\
\bar{M}_{3,4}^{(\bar{w}_2)} &= -3 k_{\{3,4\}} \bar{\psi}_{\{3,4\}}^{(\bar{w}_2)} = -3 \frac{EI}{8} (-0,002\,5) = 18,98 \text{ kNm} \\
-\bar{M}_{3,1}^{(\bar{w}_2)} - \bar{M}_{3,4}^{(\bar{w}_2)} &= -18,98 \text{ kNm} \\
-\frac{1}{4} (\bar{M}_{1,3}^{(\bar{w}_2)} + \bar{M}_{3,1}^{(\bar{w}_2)} + \bar{M}_{2,4}^{(\bar{w}_2)}) - \frac{3}{32} \bar{M}_{3,4}^{(\bar{w}_2)} &= -1,78 \text{ kNm}
\end{aligned}$$

sustav jednažbi za  $\bar{w}_2$  i rješenje:

$$27\,843,75 \varphi_3^{(\bar{w}_2)} + 8\,305,66 u_{\{3,4\}}^{(\bar{w}_2)} = -18,98$$

$$8\,305,66 \varphi_3^{(\bar{w}_2)} + 4\,622,99 u_{\{3,4\}}^{(\bar{w}_2)} = -1,78$$

$$\varphi_3^{(\bar{w}_2)} = -0,001\,22 \quad \& \quad u_{\{3,4\}}^{(\bar{w}_2)} = 0,001\,809 \text{ m}$$

vrijednosti momenata na krajevima štapova za  $\bar{w}_2$ :

$$\begin{aligned} M_{1,3}^{(\bar{w}_2)} &= 10\,125 \varphi_3^{(\bar{w}_2)} + 7\,593,75 u_{\{3,4\}}^{(\bar{w}_2)} + \bar{M}_{1,3}^{(\bar{w}_2)} \\ &= 10\,125 \cdot (-0,001\,22) + 7\,593,75 \cdot 0,001\,809 + 0 = 1,38 \text{ kNm} \end{aligned}$$

$$\begin{aligned} M_{3,1}^{(\bar{w}_2)} &= 20\,250 \varphi_3^{(\bar{w}_2)} + 7\,593,75 u_{\{3,4\}}^{(\bar{w}_2)} + \bar{M}_{3,1}^{(\bar{w}_2)} \\ &= 20\,250 \cdot (-0,001\,22) + 7\,593,75 \cdot 0,001\,809 + 0 = -10,97 \text{ kNm} \end{aligned}$$

$$\begin{aligned} M_{3,4}^{(\bar{w}_2)} &= 7\,593,75 \varphi_3^{(\bar{w}_2)} + 711,91 u_{\{3,4\}}^{(\bar{w}_2)} + \bar{M}_{3,4}^{(\bar{w}_2)} \\ &= 7\,593,75 \cdot (-0,001\,22) + 711,91 \cdot 0,001\,809 + 18,98 = 11,0 \text{ kNm} \end{aligned}$$

$$M_{2,4}^{(\bar{w}_2)} = 3\,037,5 u_{\{3,4\}}^{(\bar{w}_2)} + \bar{M}_{2,4}^{(\bar{w}_2)} = 3\,037,5 \cdot 0,001\,809 + 0 = 5,49 \text{ kNm}$$

(„neravnoteža” u čvoru 3 posljedica je pogrešaka zaokruživanja)

plan pomaka i dijagram projekcija pomaka na os štapova {2, 4} za  $t_s$ :

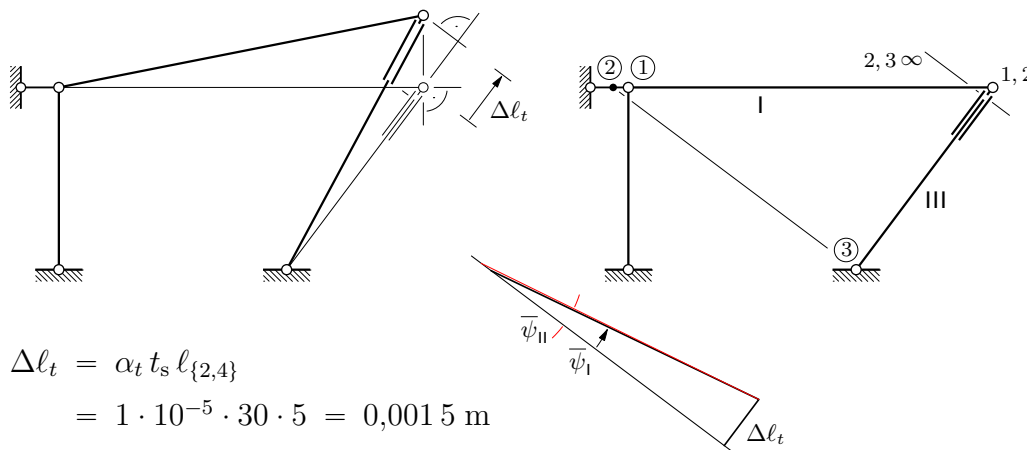

$$\begin{aligned} \Delta \ell_t &= \alpha_t t_s \ell_{\{2,4\}} \\ &= 1 \cdot 10^{-5} \cdot 30 \cdot 5 = 0,001\,5 \text{ m} \end{aligned}$$

$$\bar{\psi}_{\{1,3\}}^{(t_s)} = 0$$

$$\bar{\psi}_{\{2,4\}}^{(t_s)} = \bar{\psi}_{\text{II}} = \frac{\Delta \ell_t}{\bar{\ell}_1} = 0,000\,225$$

$$\bar{\ell}_1 \text{ — udaljenost polova 2 i 3: } \bar{\ell}_{1/5} = 4/3 \Rightarrow \bar{\ell}_1 = 20/3 = 6,6 \text{ m}$$

$$\bar{\psi}_{\{3,4\}}^{(t_s)} = \bar{\psi}_I = \frac{\Delta \ell_t}{\bar{\ell}_2} = 0,000\,234$$

$$\bar{\ell}_2 \text{ — udaljenost pola 1 od osi štapova } \{2, 4\}: \bar{\ell}_{2/8} = 4/5 \Rightarrow \bar{\ell}_2 = 32/5 = 6,4 \text{ m}$$

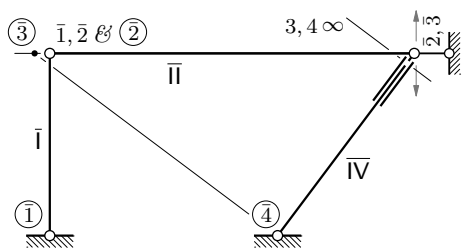

dijagrami projekcija i plan pomakā jednaki su za mehanizme prikazane na lijevom crtežu i na crtežu na prethodnoj stranici iz istih razloga kao na stranica 3 i 4

vrijednosti momenata upetosti za  $t_s$ :

$$\bar{M}_{1,3}^{(t_s)} = \bar{M}_{3,1}^{(t_s)} = 0$$

$$\bar{M}_{2,4}^{(t_s)} = -3 k_{\{2,4\}} \bar{\psi}_{\{2,4\}}^{(t_s)} = -3 \frac{EI}{5} 0,000 225 = -2,73 \text{ kNm}$$

$$\bar{M}_{3,4}^{(t_s)} = -3 k_{\{3,4\}} \bar{\psi}_{\{3,4\}}^{(t_s)} = -3 \frac{EI}{8} 0,000 234 = -1,78 \text{ kNm}$$

$$-\bar{M}_{3,1}^{(t_s)} - \bar{M}_{3,4}^{(t_s)} = 1,78$$

$$-\frac{1}{4} (\bar{M}_{1,3}^{(t_s)} + \bar{M}_{3,1}^{(t_s)} + \bar{M}_{2,4}^{(t_s)}) - \frac{3}{32} \bar{M}_{3,4}^{(t_s)} = 0,85$$

sustav jednadžbi za  $t_s$  i rješenje:

$$27 843,75 \varphi_3^{(t_s)} + 8 305,66 u_{\{3,4\}}^{(t_s)} = 1,78$$

$$8 305,66 \varphi_3^{(t_s)} + 4 622,99 u_{\{3,4\}}^{(t_s)} = 0,85$$

$$\varphi_3^{(t_s)} = 1,957 \cdot 10^{-5} \quad \& \quad u_{\{3,4\}}^{(t_s)} = 0,000 149 \text{ m}$$

vrijednosti momenata na krajevima štapova za  $t_s$ :

$$\begin{aligned} M_{1,3}^{(t_s)} &= 10 125 \varphi_3^{(t_s)} + 7 593,75 u_{\{3,4\}}^{(t_s)} + \bar{M}_{1,3}^{(t_s)} \\ &= 10 125 \cdot 1,957 \cdot 10^{-5} + 7 593,75 \cdot 0,000 149 + 0 = 1,33 \text{ kNm} \end{aligned}$$

$$\begin{aligned} M_{3,1}^{(t_s)} &= 20 250 \varphi_3^{(t_s)} + 7 593,75 u_{\{3,4\}}^{(t_s)} + \bar{M}_{3,1}^{(t_s)} \\ &= 20 250 \cdot 1,957 \cdot 10^{-5} + 7 593,75 \cdot 0,000 149 + 0 = 1,53 \text{ kNm} \end{aligned}$$

$$\begin{aligned} M_{3,4}^{(t_s)} &= 7 593,75 \varphi_3^{(t_s)} + 711,91 u_{\{3,4\}}^{(t_s)} + \bar{M}_{3,4}^{(t_s)} \\ &= 7 593,75 \cdot 1,957 \cdot 10^{-5} + 711,91 \cdot 0,000 149 - 1,78 = -1,53 \text{ kNm} \end{aligned}$$

$$M_{2,4}^{(t_s)} = 3 037,5 u_{\{3,4\}}^{(t_s)} + \bar{M}_{2,4}^{(t_s)} = 3 037,5 \cdot 0,000 149 - 2,73 = -2,28 \text{ kNm}$$

ukupne vrijednosti momenata na krajevima štapova i momentni dijagram:

$$M_{1,3} = M_{1,3}^{(\bar{u}_2)} + M_{1,3}^{(\bar{w}_2)} + M_{1,3}^{(t_s)} = 47,04 + 1,38 + 1,33 = 49,75 \text{ kNm}$$

$$M_{3,1} = 28,81 - 10,97 + 1,53 = 19,37 \text{ kNm}$$

$$M_{3,4} = -28,81 + 11,0 - 1,53 = -19,34 \text{ kNm}$$

$$M_{2,4} = -65,03 + 5,49 - 2,28 = -61,85 \text{ kNm}$$

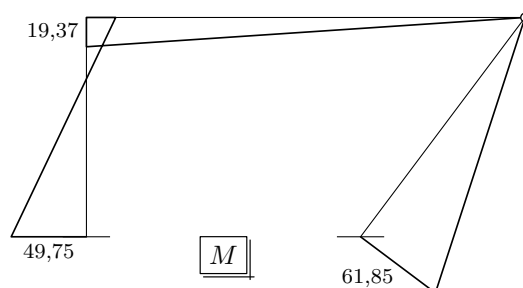

vrijednosti poprečnih i uzdužnih sila i dijagrami:

$$T_{3,1} = \frac{M_{1,3} + M_{3,1}}{4} = \frac{49,75 + 19,37}{4} = 17,28 \text{ kN}$$

$$T_{4,3} = \frac{M_{3,4}}{8} = -\frac{19,37}{8} = -2,42 \text{ kN}$$

$$T_{4,2} = \frac{M_{2,4}}{5} = -\frac{61,85}{5} = -12,37 \text{ kN}$$

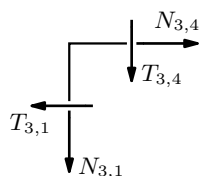

$$-T_{3,1} + N_{3,4} = 0 \Rightarrow N_{3,4} = T_{3,1} = 17,28 \text{ kN}$$

$$N_{3,1} + T_{3,4} = 0 \Rightarrow N_{3,1} = -T_{3,4} = 2,42 \text{ kN}$$

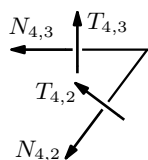

$$-T_{4,3} - \frac{3}{5} T_{4,2} + \frac{4}{5} N_{4,2} = 0 \Rightarrow N_{4,2} = \frac{5}{4} \left( T_{4,3} + \frac{3}{5} T_{4,2} \right)$$

$$N_{4,2} = \frac{5}{4} \left( -2,42 - \frac{3}{5} \cdot 12,37 \right) = -12,30 \text{ kN}$$

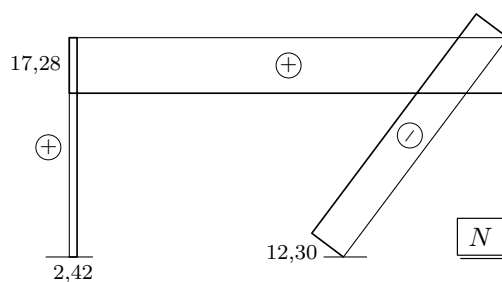
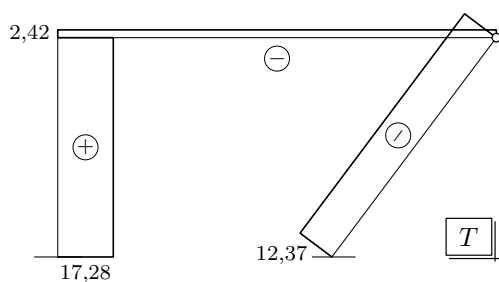

drugi način rješavanja: nepoznanice  $\varphi_3$  i  $w_4$

plan pomakā i dijagrami projekcija pomakā za  $w_4$ :

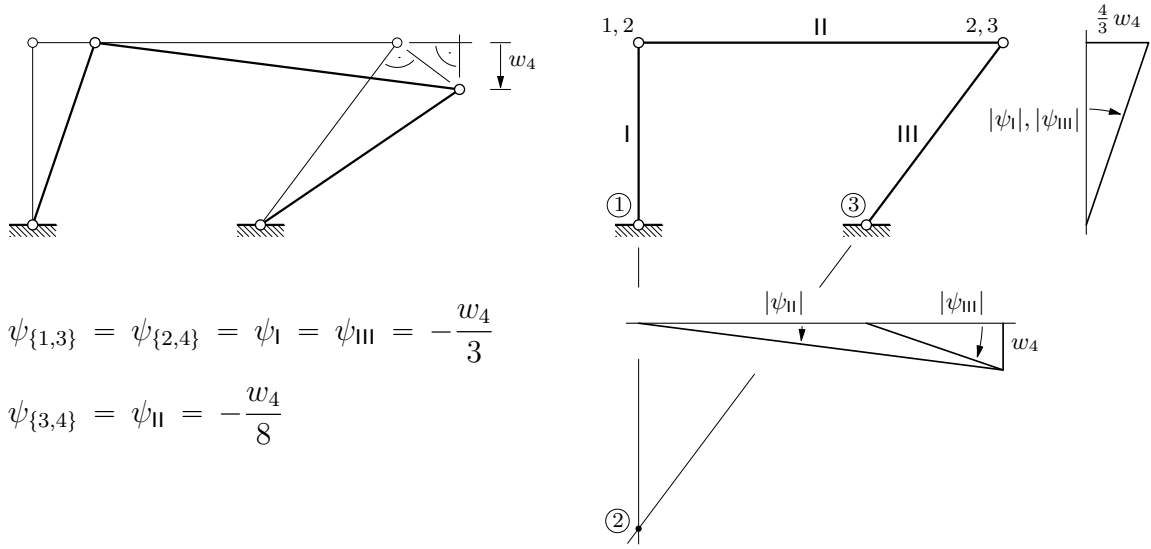

$$\psi_{\{1,3\}} = \psi_{\{2,4\}} = \psi_I = \psi_{III} = -\frac{w_4}{3}$$

$$\psi_{\{3,4\}} = \psi_{II} = -\frac{w_4}{8}$$

(naravno, konačni je crtež, osim dodanoga dijagrama projekcija pomakā na vertikalni pravac (od kojega u stvari sada sve počinje), isti kao za nepoznanicu  $u_{\{3,4\}}$  na prvoj stranici; sada je, međutim,  $w_4$  „vodeći pomak”, pa su kutovi  $\psi_{\{i,j\}}$  izraženi u ovisnosti o njemu)

izrazi za vrijednosti momenata na krajevima štapova (s nepoznanicom  $w_4$ ):

$$\begin{aligned} M_{1,3} &= 2 k_{\{1,3\}} \varphi_3 - 6 k_{\{1,3\}} \psi_{\{1,3\}} + \bar{M}_{1,3} = 2 \frac{EI}{4} \varphi_3 - 6 \frac{EI}{4} \left(-\frac{w_4}{3}\right) + \bar{M}_{1,3} \\ &= \frac{EI}{2} \varphi_3 + \frac{EI}{2} w_4 + \bar{M}_{1,3} = 10\,125 \varphi_3 + 10\,125 w_4 + \bar{M}_{1,3} \end{aligned}$$

$$M_{3,1} = 4 k_{\{1,3\}} \varphi_3 - 6 k_{\{1,3\}} \psi_{\{1,3\}} + \bar{M}_{3,1} = 20\,250 \varphi_3 + 10\,125 w_4 + \bar{M}_{3,1}$$

$$\begin{aligned} M_{3,4} &= 3 k_{\{3,4\}} \varphi_3 - 3 k_{\{3,4\}} \psi_{\{3,4\}} + \bar{M}_{3,4} = 3 \frac{EI}{8} \varphi_3 - 3 \frac{EI}{8} \left(-\frac{w_4}{8}\right) + \bar{M}_{3,4} \\ &= \frac{3EI}{8} \varphi_3 + \frac{3EI}{64} w_4 + \bar{M}_{3,4} = 7\,593,75 \varphi_3 + 949,22 w_4 + \bar{M}_{3,4} \end{aligned}$$

$$\begin{aligned} M_{2,4} &= -3 k_{\{2,4\}} \psi_{\{2,4\}} + \bar{M}_{2,4} = -3 \frac{EI}{5} \left(-\frac{w_4}{3}\right) + \bar{M}_{2,4} \\ &= \frac{EI}{5} w_4 + \bar{M}_{2,4} = 4\,050 w_4 + \bar{M}_{2,4} \end{aligned}$$

jednadžba ravnoteže momenata u čvoru 3:

$$-M_{3,1} - M_{3,4} = 0 \quad \Rightarrow \quad M_{3,1} + M_{3,4} = 0$$

$$20\,250 \varphi_3 + 10\,125 w_4 + \bar{M}_{3,1} + 7\,593,75 \varphi_3 + 949,22 w_4 + \bar{M}_{3,4} = 0$$

$$27\,843,75 \varphi_3 + 11\,074,22 w_4 = -\bar{M}_{3,1} - \bar{M}_{3,4}$$

jednadžba rada na virtualnom pomaku  $\delta w_4$ :

$$(M_{1,3} + M_{3,1}) \delta\psi_{\{1,3\}} + M_{2,4} \delta\psi_{\{2,4\}} + M_{3,4} \delta\psi_{\{3,4\}} = 0$$

$$(M_{1,3} + M_{3,1}) \left(-\frac{\delta w_4}{3}\right) + M_{2,4} \left(-\frac{\delta w_4}{3}\right) + M_{3,4} \left(-\frac{\delta w_4}{8}\right) = 0 \quad \forall \delta w_4$$

$$\frac{1}{3} (M_{1,3} + M_{3,1}) + \frac{1}{3} M_{2,4} + \frac{1}{8} M_{3,4} = 0 \quad (\text{odmah pomnoženo s } -1)$$

$$\frac{1}{3} (10\,125 \varphi_3 + 10\,125 w_4 + \bar{M}_{1,3} + 20\,250 \varphi_3 + 10\,125 w_4 + \bar{M}_{3,1}) + \frac{1}{3} (4\,050 w_4 + \bar{M}_{2,4}) + \frac{1}{8} (7\,593,75 \varphi_3 + 949,22 w_4 + \bar{M}_{3,4}) = 0$$

$$11\,074,22 \varphi_3 + 8\,218,65 w_4 = -\frac{1}{3} (\bar{M}_{1,3} + \bar{M}_{3,1} + \bar{M}_{2,4}) - \frac{1}{8} \bar{M}_{3,4}$$

plan pomakā i dijagram projekcija pomakā na horizontalni pravac za  $\bar{u}_2$ :

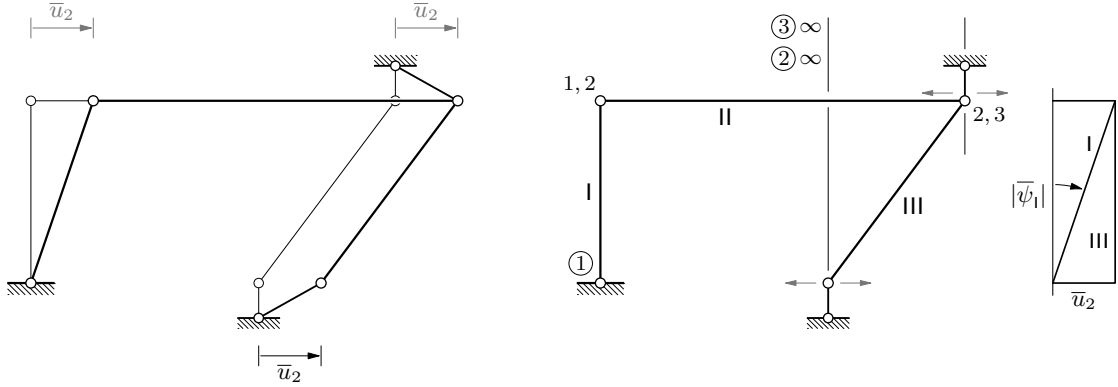

$$\bar{\psi}_{\{1,3\}}^{(\bar{u}_2)} = \bar{\psi}_I = -\frac{\bar{u}_2}{4} = -0,0075$$

$$\bar{\psi}_{\{2,4\}}^{(\bar{u}_2)} = \bar{\psi}_{\{3,4\}}^{(\bar{u}_2)} = \bar{\psi}_{II} = \bar{\psi}_{III} = 0$$

vrijednosti momenata upetosti za  $\bar{u}_2$ :

$$\bar{M}_{1,3}^{(\bar{u}_2)} = \bar{M}_{3,1}^{(\bar{u}_2)} = -6 k_{\{1,3\}} \bar{\psi}_{\{1,3\}}^{(\bar{u}_2)} = -6 \frac{EI}{4} (-0,0075) = 227,81 \text{ kNm}$$

$$\bar{M}_{2,4}^{(\bar{u}_2)} = \bar{M}_{3,4}^{(\bar{u}_2)} = 0$$

$$-\bar{M}_{3,1}^{(\bar{u}_2)} - \bar{M}_{3,4}^{(\bar{u}_2)} = -227,81$$

$$-\frac{1}{3} (\bar{M}_{1,3}^{(\bar{u}_2)} + \bar{M}_{3,1}^{(\bar{u}_2)} + \bar{M}_{2,4}^{(\bar{u}_2)}) - \frac{1}{8} \bar{M}_{3,4}^{(\bar{u}_2)} = -151,87$$

sustav jednadžbi za  $\bar{u}_2$ :

$$27\,843,75 \varphi_3^{(\bar{u}_2)} + 11\,074,22 w_4^{(\bar{u}_2)} = -227,81$$

$$11\,074,22 \varphi_3^{(\bar{u}_2)} + 8\,218,65 w_4^{(\bar{u}_2)} = -151,87$$

$$\varphi_3^{(\bar{u}_2)} = -0,001179 \quad \& \quad w_4^{(\bar{u}_2)} = -0,016062 \text{ m } \dots$$

... dalje možete sami. Znaete što morate dobiti — rješenje (osim zanemarivih razlika zbog grešaka zaokruživanja) ne ovisi o načinu rješavanja. No, budući da su dijagrami projekcija pomakā i planovi pomakā vječna vaša muka paklena, nacrtat ću ih.

plan pomakā i dijagram projekcija pomakā na vertikalni pravac za  $\bar{w}_2$ :

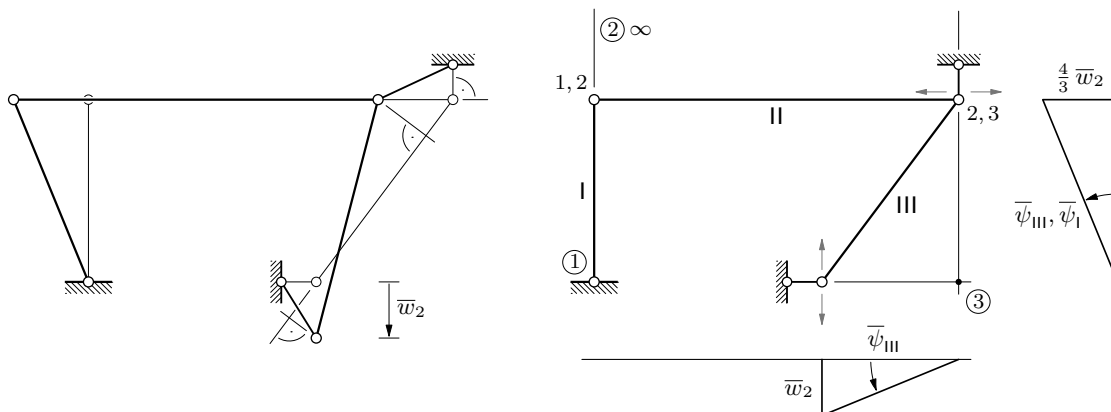

plan pomakā i dijagram projekcija pomakā na os štapa {2, 4} za  $t_s$ :

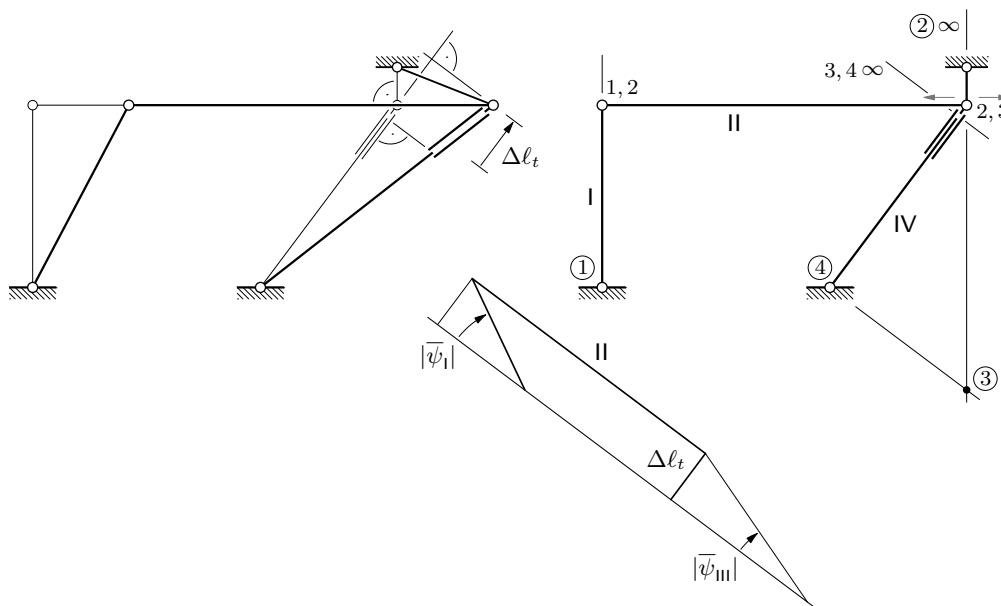

I, umjesto kraja, na sljedećim stranicama dijagrami projekcija pomakā i planovi pomakā za još jedan način rješavanja. Ne baš vjerojatan izbor „vodećega pomaka” (neovisnoga translacijskog pomaka, nepoznanice), a i neki će izrazi biti poprilično zapetljani...

treći način: nepoznanice  $\varphi_3$  i  $d_4$

plan pomakā i dijagrami projekcija pomakā za  $d_4$ :

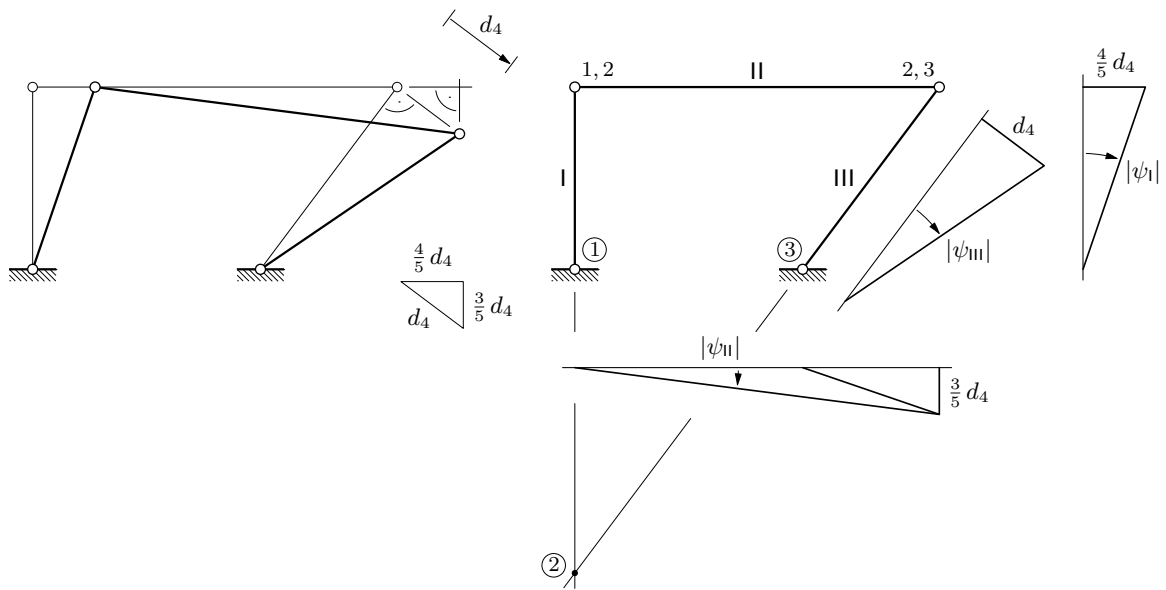

plan pomakā i dijagram projekcija pomakā na horizontalni pravac za  $\bar{u}_2$ :

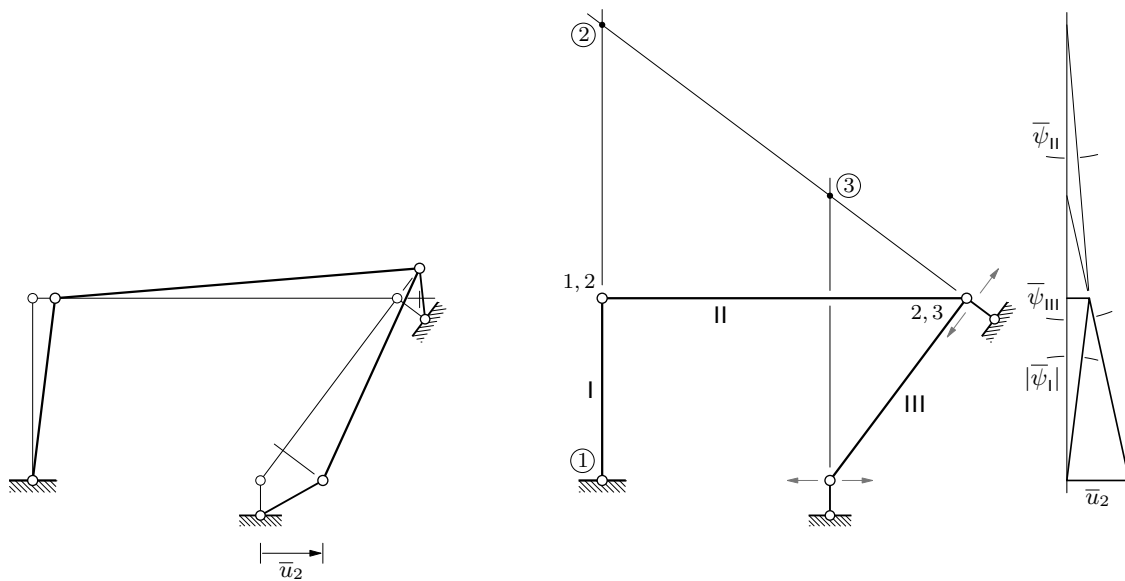

plan pomakā i dijagrami projekcija pomakā za  $\bar{w}_2$ :

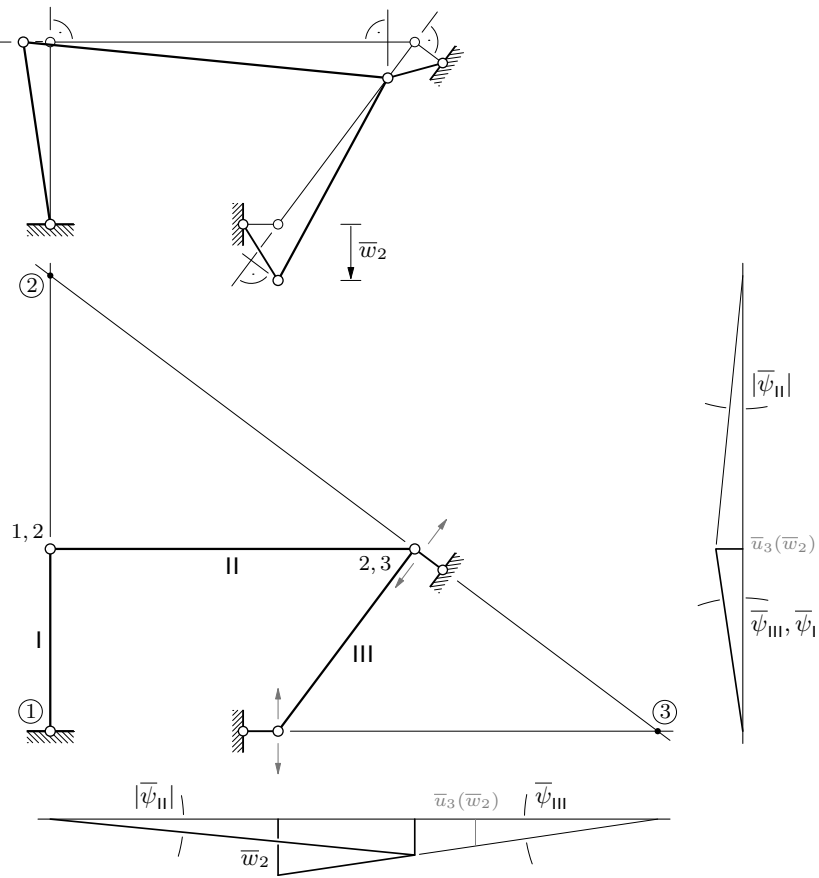

plan pomakā i dijagram projekcija pomakā na os štapa {2,4} za  $t_s$ :

